

Model ECSS 25

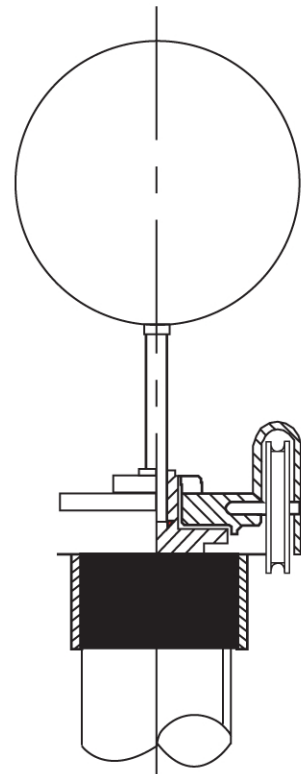
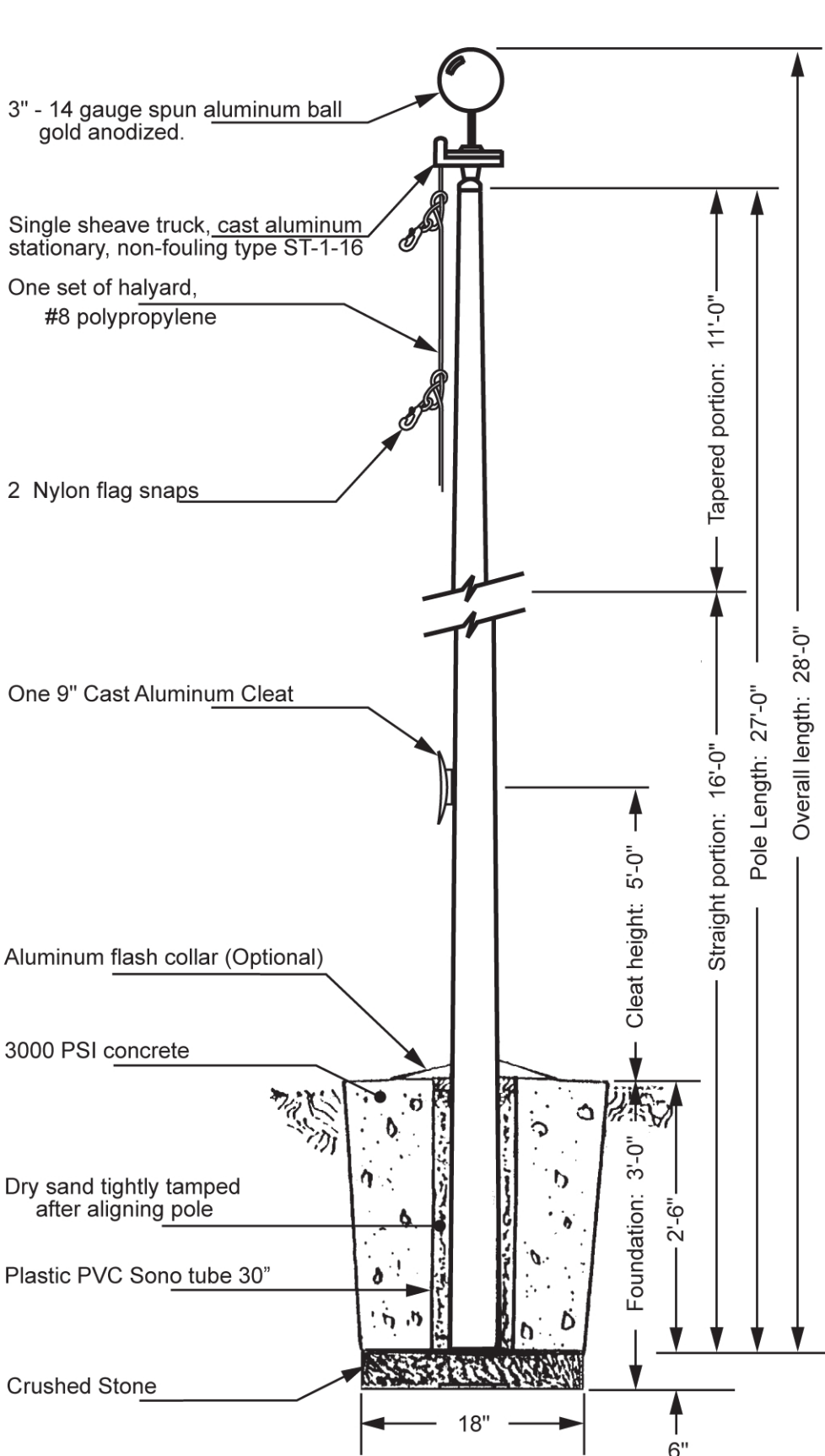

All shafts with overall length of more than 38'-6" are shipped in two sections.

Each section matched marked for field assembly. Exposed portion of jam sleeve must be **well lubricated** prior to assembly.

1-1/2" maximum shop gap allowed for field fitting (ram for tight joint)

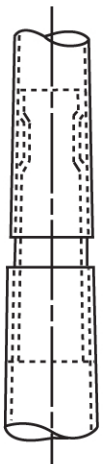

Filename: ECSS 25 stationary truck_external halyard.ai

Project:	Ground set tapered aluminum flagpole: ALLOY: 6063T6	
Location:	Exposed height: 25'-0"	Overall height: 28'-0"
Architect:	Ship in 1 section	Butt diameter: 3"
Contractor:	Top diameter: 1-7/8"	Wall thickness: .125"
Customer:	Finish: 100 grit polish	

